



KLT-USB1A-OV10635 V1.0

OmniVision OV10635 USB インターフェース 固定焦点 1MP M12 カメラモジュール



カメラモジュール番号	KLT-USB1A-OV10635 V1.0	
イメージセンサー	OV10635	Output Format: MJPG, YVY2
EFL	2.3 mm	15 FPS 1280 x 720 (HD 720P)
F.NO	2.5	15 FPS 640 x 480 (0.3MP VGA)
ピクセル	1280 x 800	15 FPS 320 x 240 (0.07MP)
視野角	170°	Supporting OS
レンズタイプ	1/2.7 インチ	Windows 7, 8.1, 10, Vista
レンズ寸法	13.70 x 13.70 x 20.92 mm	Windows XP SP2 under UVC
モジュールサイズ	30.50 x 28.50 mm	Linux Kernel V2.6.2.1 or later
モジュールのタイプ	固定焦点	MAC OS 10.4 or later
インターフェース	USB 2.0	Operating Voltage: 5V +/- 5%
IMT レンズモデル	IMT-1B12E005-6	Compliant with UVC Version 1.0

嵌合USBケーブル部品番号: **KLT-USB1A-Cable**



USBケーブル延長コード。別売りされている。

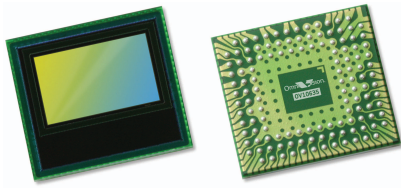

OV10635 HD HDR product brief



Megapixel, Color HDR Sensors for Advanced Automotive Display and Sensing Applications



available in a lead-free package

The OV10635 system-on-chip (SoC) sensor raises the standard in automotive imaging by combining megapixel resolution with color HDR. The AEC-Q100 qualified OV10635 comes with a full set of automatic controls and an image processing pipeline for display and sensing applications. Ideally suited for wide field of view and multi-camera applications, the OV10635 also incorporates special features and output formats for automotive machine vision applications. With its proprietary capability to simultaneously deliver high image quality and superior scene information, the OV10635 is designed for automotive applications that perform vision and sensing functions in tandem.

The sensor is built on a 4.2-micron OmniPixel3-HS™ pixel, enabling best-in-class low-light sensitivity of 3.65 V/lux-sec to capture detail-rich, high-definition color video in any environment. Using a proprietary new high dynamic range (HDR) concept and processing technology, this automotive sensor delivers excellent scene reproduction in the most demanding lighting conditions, achieving a dynamic range up to 115 dB in color and black-and-white. The OV10635 not only has the ability to accurately reproduce high-contrast scenes, but also employs auto dynamic range control to adjust to changing lighting and scene conditions to produce a clear, detailed and low-noise

color image in any automotive situation. A proprietary approach to generating HDR images also dramatically reduces or eliminates many typical HDR image sensor artifacts such as motion ghost artifacts and other unwanted effects.

The OV10635 offers all required automatic image control functions, including automatic exposure control, automatic white balance, automatic black level calibration, as well as defective pixel correction, gamma correction and lens shading correction. The sensor supports a digital video parallel port, and provides full-framed or windowed 10- or 8-bit YUV and 10- to 18-bit combined HDR RAW output format with complete user control over formatting and output data transfer.

Camera functions are programmable through the serial camera control bus (SCCB) interface. Additional features include a horizontal and vertical windowing capability, external frame sync capability, 50/60 Hz flicker cancellation and low power consumption.

The OV10635 comes in a 7.8 mm x 7.1 mm aCSP package.

Find out more at www.ovt.com.

Applications

- Automotive
 - 360° surround view
 - automotive machine vision
 - lane departure warning
 - traffic sign recognition
 - automatic high beam control
 - object detection
- pedestrian detection
- rear view camera
- blind spot detection
- mirror replacement
- occupant sensor
- night vision

Product Features

- support for image sizes:
 - WXGA (1280x800)
 - HD 720p (1280x720)
 - WVGA (752x480)
 - VGA (640x480)
 - 600x400
 - CIF (352x288)
 - QVGA (320x240)
- support for output formats: YUV and separated and combined RAW
- parallel DVP interface
- high sensitivity
- automatic exposure/gain
- horizontal and vertical windowing capability
- auto white balance control
- aperture/gamma correction
- serial camera control bus (SCCB) for register programming
- low power consumption
- external frame sync capability
- 50/60 Hz flicker cancellation
- defective pixel correction

OV10635/OV10135

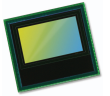

Ordering Information

- OV10635-N29Y-PB**
(color sensor with protective film in tray, lead-free, 129-pin aCSP™)
- OV10635-N29Y-RB**
(with protective film in tape and reel, lead-free, 129-pin aCSP™)
- OV10135-N29Y**
(b&w sensor with protective film in tray, lead-free, 129-pin aCSP™)

Product Specifications

- active array size:** 1280 x 800
- lens chief ray angle:** 9°
- power supply:**
 - core: 1.425 - 1.575V
 - analog: 3.14 - 3.47V
 - I/O: 1.7 - 3.47V
- power requirements:**
 - active: 485 mW typical @ 3.3V AVDD, 1.5V DVDD, and 1.8V DOVDD
 - standby: 267 μW typical @ 3.3V AVDD, 1.5V DVDD, and 1.8V DOVDD
- temperature range:**
 - operating: -40°C to +105°C sensor ambient temperature (operating sensor ambient temperatures above +60°C may result in degraded image quality)
- output interfaces:** 10-bit parallel DVP
- output formats:** up to 18-bit combined RAW, separated 10-bit RAW, 8-/10-bit YUV422
- lens size:** 1/2.7"
- input clock frequency:** 6 - 27 MHz
- max S/N ratio:** 39 dB
- dynamic range:** 115 dB
- maximum image transfer rate:** 30 fps full resolution
- sensitivity:** 3650 mV/lux-sec
- scan mode:** progressive
- shutter:** rolling shutter
- maximum exposure interval:** 838 x t_{row}
- pixel size:** 4.2 μm x 4.2 μm
- dark current:** 2.5 mV/s @ 50°C junction temperature
- image area:** 5510.4 μm x 3418.8 μm
- package dimensions:**
 - aCSP™: 7795 μm x 7145 μm

Functional Block Diagram

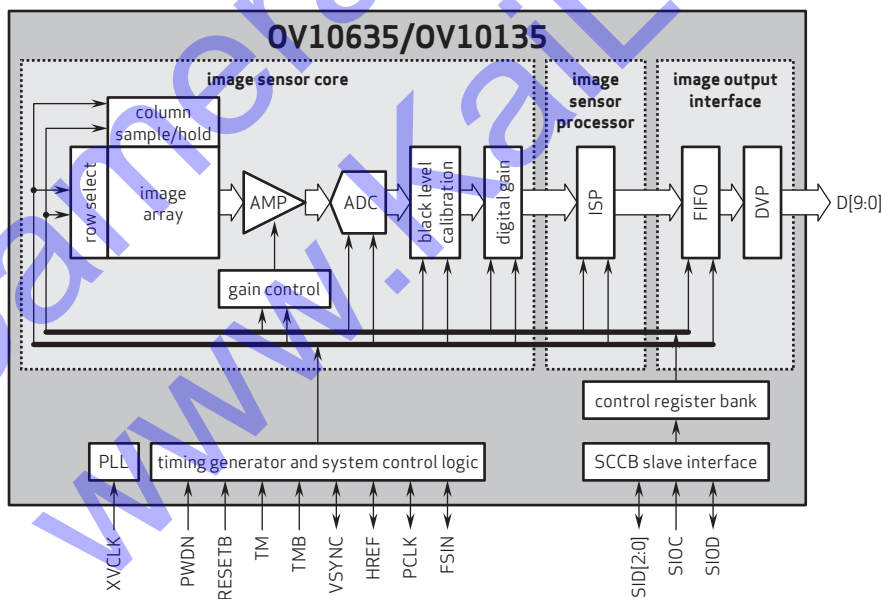

4275 Burton Drive
Santa Clara, CA 95054
USA

Tel: + 1 408 567 3000
Fax: + 1 408 567 3001
www.ovt.com

OmniVision reserves the right to make changes to their products or to discontinue any product or service without further notice. OmniVision and the OmniVision logo are registered trademarks of OmniVision Technologies, Inc. OmniBSI is a trademark of OmniVision Technologies, Inc. All other trademarks are the property of their respective owners.

